

Degrading Chilled Water Plant Delta-T: Causes and Mitigation

Steven T. Taylor, P.E.

Member ASHRAE

ABSTRACT

Variable-flow chilled water plants are designed to maintain a relatively constant delta-T, the difference between return and supply chilled water temperature. But in almost every real chiller plant, delta-T falls well short of design levels. The result is that flow and load do not track, usually requiring that additional chillers be brought on line to maintain flow requirements even though none of the chillers is fully loaded. Both pump energy and chiller energy increase accordingly. Many design and retrofit measures have been tried to resolve the problem, but they are sometimes expensive and not always successful. In this paper, the author argues that while many causes of degrading delta-T may be eliminated, in most plants it is not possible to avoid degrading delta-T under all operating conditions. Several design and operational techniques are presented both to minimize degrading delta-T and to design plants to be efficient despite degrading delta-T.

INTRODUCTION

In most variable-flow chilled water plants, it is assumed that delta-T, the difference between return and supply chilled water temperature, will remain relatively constant. Because the load is directly proportional to flow rate and delta-T (Equation 1), if the delta-T is constant, it follows that flow rate must vary proportionally with the load. Most variable-flow systems are designed based on this assumption and usually fail to perform well if the delta-T does not stay relatively constant.

$$Q = \dot{m}c_p\Delta T$$

$$Q(\text{Btu/h}) = 500 \text{ GPM } \Delta T \text{ (IP units)} \quad (1)$$

$$Q(\text{kW}) = \text{LPS } \Delta T \text{ (SI units)}$$

In almost every real chiller plant, delta-T falls well short of design levels, particularly at low loads. The result is higher pump and chiller energy usage. Many papers have been written on the subject of “low delta-T syndrome” (Kirsner 1996, 1995; Lizardos 1994; Sauer 1989; Fiorino 1996; Avery 1997; Mannion 1988). Most are oriented toward how to keep delta-T high. This paper also will address causes of degrading delta-T along with mitigation measures, but it goes on to show why delta-T degradation will almost always occur in chilled water systems and how to design around that eventuality to maintain chiller plant efficiency despite degrading delta-T.

THE ENERGY IMPACT OF DEGRADING DELTA-T

Figure 1 shows a hypothetical chiller plant serving several buildings in a large facility, such as a university campus, office complex, district cooling system, or industrial facility. The system is piped in a traditional primary-secondary manner with some tertiary pumps at remote buildings.

If the delta-T in this system is low, at least two problems result: increased pump energy usage and either an increase in chiller energy usage or a failure to meet cooling loads.

The increase in pump energy is obvious. According to Equation 1, any reduction in delta-T must cause a proportional increase in chilled water flow rate. Pump energy, theoretically, is proportional to the cube of the flow rate, so any increase in flow will have a much higher increase in pump energy. In real

Steven T. Taylor is a principal at Taylor Engineering, Alameda, California.

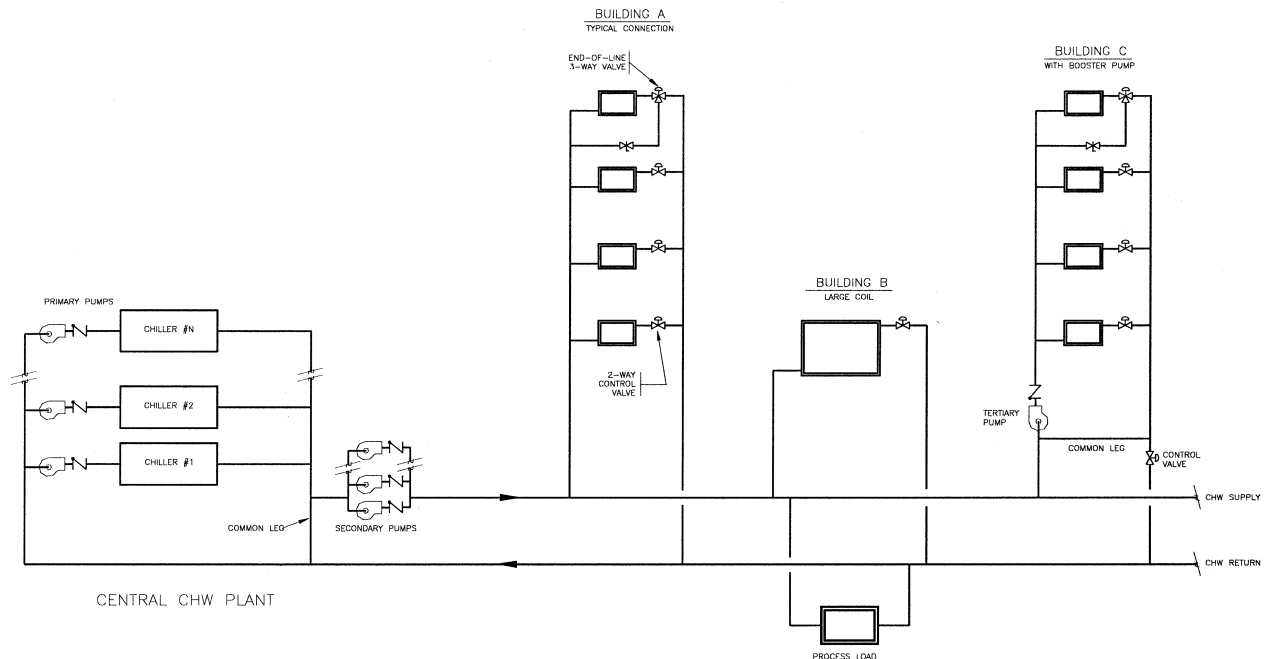

Figure 1 Typical chilled water plant and distribution system.

systems, actual pump energy impact will be less than this theoretical relationship suggests,¹ but the impact is significant nonetheless.

The impact on chiller energy usage is more complex to determine and will be a function of how the chillers are controlled. There are two basic chiller start/stop control strategies, one based on system flow rate and the other based on load. Ideally, the two strategies would be effectively the same since flow and load should track in a variable-flow system. However, when flow and load do not track, when delta-T falls, neither strategy works ideally.

The flow-based strategies stage chillers and primary chilled water pumps in an attempt to keep the primary system flow larger than the secondary system flow. In this way, the secondary supply water temperature is equal to the primary water temperature leaving the chillers. Flow is often sensed in

the common leg or in the primary and secondary supplies from which flow in the common leg can be deduced. When flow in the secondary exceeds the primary, as indicated by flow in the common leg moving from the secondary return toward the secondary pumps, another primary chilled water pump and chiller are started. A pump and chiller are shut off when flow in the common leg exceeds that of one pump, with some additional margin to prevent short cycling.

The load-based strategy measures system load or indirect indications of load such as return water temperature. Chillers are started when the operating chillers are operating at their maximum capacity. Chillers are stopped when the measured load is less than the operating capacity by the capacity of one chiller.

So what happens when delta-T falls below design levels and flow and load are no longer in synch?

The flow-based control system will always make sure loads are met by starting additional chillers and pumps to keep the primary system flow larger than the secondary flow. But this means that chillers are not fully loaded when delta-T is below design. For example, assume the system was sized for a 14°F delta-T on both the primary and secondary sides. If the system were at 50% load but the actual delta-T was only 7°F, all the chillers and primary pumps in the plant would have to operate to keep the primary flow up. This wastes pump energy and chiller energy since the chillers would all be operating at 50% of capacity, less than the 65% to 85% range where efficiency is typically maximized for fixed-speed chillers.

The load-based control system would not start a new chiller until the operating chillers were loaded. As delta-T degrades, secondary flow increases, causing water in the

¹ The cubic relationship between pump energy and flow assumes that pressure drop varies as the square of fluid velocity, an assumption valid only for fully developed turbulent flow in systems with fixed geometry. In real systems, pressure drop in most system elements varies less than this since flow is not fully turbulent; velocities are more typically in the transitional region between turbulent and laminar flow at design load conditions and in the laminar flow regime at low loads. Control valves open and close, changing system geometry and, hence, its flow characteristics. Most variable-speed pumping systems maintain a minimum differential pressure setpoint, further changing the pressure drop/flow relationship. Finally, motor efficiency and (to a lesser extent) variable-speed drive efficiency drop off at lower loads. All of these factors combine to make part-load pump energy savings less than what may be expected from the ideal cube-law relationship.

TABLE 1
Coil Performance at Low SAT Setpoints

Leaving Air Temperature Setpoint, °F	Flow Rate, gpm	CHW Delta-T, °F	% of Design GPM
54	80	13	100%
53	104	11	130%
52	143	8.5	179%
51	208	6.5	260%
50	327	4.3	409%
49	cannot be attained		
Based on a six-row 100 fpf coil, 78°F entering dry-bulb 63°F entering wet-bulb.			

common leg to flow from the secondary return back into the secondary pumps. This causes the secondary supply water temperature to rise, which in turn causes coil performance to degrade, which in turn causes control valves to open more to demand more flow, which in turn causes ever increasing flow in the secondary and ever warmer supply water temperatures. Eventually, coils will starve, their control valves will be wide open, and temperature control is lost. The system controlling chiller staging would be oblivious to these problems; it would not start more pumps and chillers since the operating chillers were not fully loaded.

The solution to these problems lies in first maximizing delta-T as much as possible but then designing the plant to accommodate the low delta-Ts that will inevitably occur.

DEGRADING DELTA-T: CAUSES AND MITIGATION

The causes of degrading delta-T can be broken into three categories:

- Causes that can be avoided by proper design or operation of the chilled water system
- Causes that can be mitigated or resolved but through measures that may not result in overall energy savings
- Causes that are inevitable and simply cannot be avoided

CAUSES THAT CAN BE AVOIDED

Improper Setpoint or Controls Calibration

Probably the most common cause of low delta-T is improper setpoints on controllers controlling supply air temperature off of cooling coils such as those in VAV systems and other central fan systems. When the setpoint of a cooling coil is set too low, the controller causes the chilled water valve to open fully since it is unable to attain the setpoint no matter how much chilled water flows through the coil. Table 1 shows how even a modest drop in supply air temperature setpoint from 54°F to 51°F can cause coil flow rate to more than double and delta-T to drop in half (see also example in Kirsner 1995).

Setpoints are often adjusted downward by building engineers trying to resolve a comfort problem quickly, although this is seldom the real source of the problem. In the author’s experience, coils are seldom undersized. Cooling shortages are more typically due to undersized zone terminal boxes or ductwork to those boxes and to the inability of the supply fan to overcome the resulting high pressure drop to these zones.

A similar effect can be caused by improper sensor or controller calibration. The controller may be set to a proper setpoint on the dial, but improper calibration may cause the system to try to achieve a much lower actual setpoint.

Mitigation: Check setpoints regularly and adjust to design levels or higher. If the control system is digital, “lock” setpoint ranges in software to prevent operators from setting overly low setpoints. Calibrate sensors and controllers semi-annually or annually. This is particularly true when pneumatic controls are used, but even the RTDs and thermistors used with modern digital control systems drift over time and must be recalibrated regularly.

The problem of exceeding design flow rates when valves are wide open can be resolved by installing automatic flow control valves, which are self-powered valves that maintain a preset maximum flow regardless of the differential pressure across them (within certain limits). These valves, however, add considerable cost and pressure drop to the system, both due to the valves themselves and to the strainers that are often required in front of them to prevent valve clogging. Also, these valves can only prevent flow from exceeding design rates; an improper setpoint can still result in considerable bypass of water above what is actually “used” in the coil at low-load conditions even though flow is limited.

Use of Three-Way Valves

Three-way valves always have a negative impact on delta-T and almost always can and should be avoided.

Three-way valves theoretically maintain constant flow and, hence, delta-T will vary proportionally with the load. In fact, three-way valves will cause an increase in flow at part load and thus have an even worse impact on delta-T than one might think.

One reason for this is the often missing or unbalanced valve in the coil bypass leg of the three-way valve connection. This valve is absolutely required except where coil pressure drops are very low (e.g., reheat coils). When properly balanced, the valve is throttled down to match the coil pressure drop so that when the three-way valve is in either the flow-through-coil or flow-through-bypass positions, the pumping system will see the same pressure drop. It seems that most three-way valve installations the author has observed either have no valve in the bypass or the valve is wide open, indicating that it was never balanced. The impact of either condition is that at part load, when flow is bypassed around the coil, a hydronic short-circuit occurs, i.e., supply water is directly injected into the return. Flow increases above design rates and

differential pressure in the system drops, possibly starving other coils.

Even when the bypass valve is properly balanced, flow will only remain at design rates when the control valve is fully open or fully closed to the coil. When the control valve is in between these two extremes, flow will always increase because pressure drop through each circuit varies approximately as the square of the flow rate. Therefore, when the valve is in the 50% mixing position, the flow rate will approximately double, not remain constant as desired. This will further degrade delta-T.

Mitigation: The bottom line is: never use three-way valves in variable-flow systems, except perhaps for one or two valves to ensure that pumps are never dead-headed. This includes one of the most common misapplications: the so-called end-of-line three-way valve (see Buildings A and C in Figure 1) intended to keep water constantly moving through the circuit. The argument for end-of-line three-way valves is that they will ensure chilled water will be available immediately on demand by any coil in the system. The concept probably comes from domestic water recirculating systems, which are designed to make sure people do not have to wait to get hot water at a lavatory. But the concept is not applicable to most chilled water systems simply because it seldom matters if coils have to wait a few seconds or a few minutes to get chilled water when they call for it. For instance, assume a system located one mile from the central plant has been operating on economizer, then the outdoor air temperature rises 1°F so that some chilled water is needed to maintain desired supply air temperatures. At typical piping velocities, it may take only about 10 minutes for water to travel the one mile from the plant to the coil. Surely, the building will not go out of control in 10 minutes. Had the system had its own chiller, it might take that long to start the system and cool down the mass of water within it. For the more typical close-coupled chilled water distribution system, the waiting time will be much less than 10 minutes and even less likely to be of concern. Thus, unless some process load requires instantaneous chilled water, or if the chilled water plant serves buildings very far away, end-of-line three-way valves are not necessary and should be avoided.

Improper Coil Selection

Probably the most common coil selection error is simply selecting the coil for a delta-T that is lower than the plant design delta-T. Buildings in a multi-building campus are often designed by different engineers. For some reason, some engineers “are not with the program” and do not use the correct delta-T in their coil selections. For example, a plant may be designed for a 14°F delta-T, but the engineer of one building served by the plant selects coils based on a “standard” 10°F delta-T simply out of ignorance or laziness.

Low delta-T also can also be caused by coils selected to minimize coil water-side pressure drop. One way to reduce coil pressure drop is to select a “dual row” coil, one that is piped with the water entering at two coil locations (last row

and middle row), rather a standard “full row” coil where the water enters only into the last row of the coil (the row at the air discharge side of the coil). The dual-row coil has lower tube velocity and, hence, lower water-side pressure drop than the standard coil. But (as pointed out in the laminar flow discussion below), high water velocity will improve coil part-load performance. Figure 7 shows how the dual-row coil has a lower delta-T at part load than full row coils, and flow falls into the transition and laminar flow regimes sooner because of the lower initial velocity.

Mitigation: Document the plant design delta-T and chilled water supply temperature well and ensure that designers select coils for equal or higher delta-Ts. Selecting coils based on a somewhat higher than design chilled water supply temperature (e.g., 1°F to 2°F higher) is prudent to account for coil fouling over time. Some exceptions should be allowed, however. While high delta-Ts are favorable in reducing water-side costs and energy usage, they are detrimental to air-side (fan) energy usage. Achieving larger water-side delta-Ts requires more heat transfer area (more rows and fins), which results in higher fan pressure drops and higher fan energy. The ideal balance between water-side and air-side considerations will vary with each fan system, and it may be that in some cases, delta-T should be sacrificed for reduced air-side pressure drop. A detailed discussion of this trade-off is beyond the scope of this paper (see Taylor et al. 2000).

Coils should almost always have “full row” headers to maintain high part-load delta-Ts, although again, some exceptions should be considered. The question is whether the reduction in pump head achieved with the dual-row coils will offset the higher flow rates required at part load. The answer depends on the specifics of the system design, how pumps are controlled, whether the coil is part of the circuit determining pump head, how many hours the system is at each part-load point, etc.

Coil selection parameters need not be the same for each coil. The best design may be to use dual-row coils on the hydraulically longest runs to reduce pump head, then compensate by using higher delta-T coils on circuits closer to the pump where excess head is available.

Improperly Selected Control Valves

Two aspects of two-way control valve selection are particularly critical for variable-flow systems: valve size (C_v) and actuator size (shutoff capability).

Proper sizing of control valves is critical in a two-way valve system, particularly when pumps are uncontrolled (riding their curves). Many designers feel that oversizing control valves is no longer a concern in modern systems with direct digital controls using PID control loops and variable-speed drives to control system pressure. This is certainly partly true, but no amount of control magic can compensate for a grossly oversized valve.

Oversized control valves cause the controller to “hunt,” alternately opening and closing the valve, over- and under-

shooting the setpoint. The overall average flow is higher than desired, and thus delta-T is reduced.

Undersizing the actuator is another common problem. Valve/actuator combinations usually have two ratings: the close-off rating is the maximum differential pressure across the valve against which the valve and actuator can completely close. The dynamic close-off pressure rating is the maximum differential pressure for modulating (as opposed to two-position) applications; above this pressure, control through the entire stroke will no longer be smooth and the design turn-down ratio will not be achieved. Often valves are selected only to achieve the required close-off rating, but they cannot provide modulating duty under high differential pressures. The result is hunting and excess water being forced through the coil.

Two-position (as opposed to modulating) control valves are often blamed for low delta-T problems. These valves, commonly used on small fan-coil units, cause flow through the coil to be either “on” (at design rate or higher) or “off”. When on, it is argued that the flow will exceed that required by the load under all conditions except design conditions, and thus water will leave the coil at less than design leaving water temperature. But in fact the impact on delta-T is not great, and it may even be better than for modulating flow under low-load conditions. The leaving water temperature at low load is not low because the valve will only stay open long enough to satisfy the load. Assuming flow is balanced (i.e., limited to design flow by flow control valves or a self-balancing system layout), delta-T is negatively affected only by the lower entering air temperature to the coil. But coil entering air temperature is fairly constant for most fan-coil installations because they usually supply only air returned from the space with little or no outdoor air. Thus, the delta-T will not degrade significantly at part load. On the other hand, if flow is controlled by a modulating valve, delta-T will increase at first (see Figure 7), but the transitional/laminar flow effect at low load will ultimately cause a drop in delta-T. Thus, the selection of two-position or modulating valves should be based on other considerations (e.g., cost, thermal performance), not their impact on delta-T.

Mitigation: Valve and actuator selection is beyond the scope of this paper. See Taylor (1996) for a detailed discussion of valve selection issues.

If valves do not have adequate close-off capability, one way to mitigate the problem is to control system differential pressure using a variable-speed drive on the pump. The differential pressure sensor should be located as far out into the system as possible, usually at the hydraulically most remote coil, and the setpoint should be only as high as necessary to deliver design flow rates at design conditions.

If two-position valves are used, flow must be balanced using either automatic flow-limiting valves or by designing the system to be reasonably self-balancing, e.g., using reverse-return or oversized headers. Manual balancing valves, includ-

ing calibrated balancing valves, will not work because they can only balance the system under one operating condition; the system will not maintain balance under variable-flow conditions as control valves open and close.

No Control Valve Interlock

Controls are usually designed for low cost and simplicity. As a result, it is not uncommon for valves to remain under control even when the associated air handler is off. The controller will futilely try to achieve the desired space or supply air temperature and ultimately cause the control valve to fully open, bypassing cold supply water into the return with little or no temperature rise. This is a much more common problem with pneumatic control systems, where one or more EP valves must be added and interlocked to the supply fan at considerable expense, than for digital controls where valve interlocks can be made at little cost through software.

Mitigation: Control valves must be interlocked to shut off flow when the associated air handler shuts off.

Improperly Piped Coils

It is not uncommon to find chilled water coils piped backwards. Instead of being piped in a counterflow arrangement, they are piped in a parallel-flow arrangement with water entering the coil on the same side as the entering air. A coil piped counterflow can achieve “overlapping” temperature ranges with the supply air, e.g., the leaving water temperature can enter at 44°F and leave at 60°F while the supply air enters at 80°F and leaves at 55°F. With parallel-flow piping, the two ranges cannot overlap: leaving water temperature will always be a few degrees cooler than the leaving supply air temperature. Thus, if 55°F is maintained, flow must be much higher and the return water temperature will only be in the low 50s. The desired delta-T would be impossible to attain.

Mitigation: Coils must be piped counterflow.

Improper Tertiary Connection and Control

Figure 1 shows a tertiary pump at Building C. Tertiary pumps are most commonly used:

- when the building requires greater pump head than the secondary pumps can deliver, e.g., at remote buildings (in this case, the pump is often referred to as a booster pump) and
- to maintain a warmer supply water temperature to the building. In this case, the pump is often referred to as a blending pump.

Usually, the two-way control valve in the secondary return line is modulated to maintain the supply water to the building at a given setpoint. This setpoint must be above the chilled water temperature supplied to the building or the valve will simply be opened fully by its controller in the futile

TABLE 2
Coil Performance with Increasing CHWS Temperature

Entering Chilled Water Temperature, °F	Flow Rate, gpm	Delta-T, °F	Leaving Chilled Water Temperature, °F
42	30	16.7	58.7
44	34.5	14.7	58.7
46	41	12.3	58.3
48	53	9.5	57.5

Based on an eight-row 96 fpf coil, 77°F entering dry-bulb/ 62°F entering wet-bulb, 55°F leaving air temperature.

attempt to maintain an unachievable setpoint. This bypasses chilled water from the secondary supply to the return through the common leg, severely reducing delta-T when the load on the building is low. If there is no flow-limiting device in the connection to the secondary mains (e.g., an automatic flow control valve), this bypass flow can far exceed the design flow to the building because of the low pressure drop in the common leg. This hydronic “short-circuit” also causes a drop in differential pressure across the secondary system, possibly starving other buildings that do not have tertiary pumps.

Mitigation: For retrofit applications, a simple solution is to ensure that the setpoint of the controller maintaining supply water temperature to the building is several degrees above the chilled water temperature being delivered to building. To do this, the latter temperature should be constantly monitored and the setpoint constantly adjusted to maintain the desired differential, in case the supply water temperature from the secondary system changes (e.g., reset).

This control will not help improve delta-T if the coils downstream are not maintaining a high delta-T. To resolve this problem, some designers move the temperature sensor controlling the two-way valve from the supply line to the return water line. The control valve is then modulated to maintain the return water temperature at design levels, e.g., 58°F. If return water is too cold, it is essentially recirculated back into the building to absorb more heat. This control can be effective if low delta-T is caused solely by reduced coil effectiveness at low loads and all coils are experiencing similar loads. Feeding the water back to the coils in this case delivers the same effect as the pumped coil in Figure 8 (discussed in next section). The fact that the load is low allows the water temperature to the coil to be warmer than design, so the coil should not be starved. However, while instinctively it may make sense that recirculating water will increase the return water temperature, the return water temperature is driven more by the entering air temperature and the coil effectiveness, not the entering water temperature. Table 2 shows that for a given load, increasing entering chilled water temperature results in a lower, not higher, leaving return water temperature. So recirculating water not only increases the flow in the build-

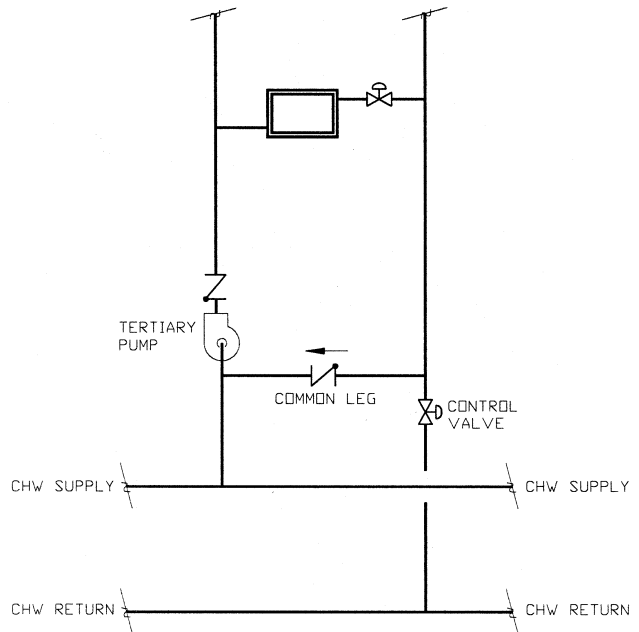

Figure 2 Check valve in common leg. Check valve only allows tertiary (building) flow to exceed secondary flow. Chilled water supply cannot short-circuit to return. Tertiary pump is in series with secondary pumps at low building flows, so tertiary pump must be variable speed driven to keep from over-pressurizing building.

ing loop, it also slightly increases flow in the secondary loop. Furthermore, this control is indirect and may inadvertently starve coils if they require design water temperature to meet loads. Clearly, this is not a good control strategy.

Another possible retrofit solution is to place a check valve in the common leg as shown in Figure 2. This ensures that chilled water supply will never be bypassed through the common leg to the return. Building water flow will always equal or exceed that supplied through the secondary system. Placing anything in the common leg, in particular a check valve, is considered heresy by some designers because the two pumping systems are then no longer hydraulically independent. This author’s response: So what? Designers have been taught that hydraulic independence has some intrinsic value, but its value is generally that it prevents series coupled pumps from overpressurizing two-way valves. In this case, the check valve will cause the secondary and tertiary pumps to operate in series when the tertiary flow is low and chilled water is still in demand (the chilled water valve on secondary return is open). This could overpressurize the tertiary loop and overpower some control valves. But the problem is resolved if the tertiary pump is variable speed driven; it will simply slow down if the secondary system differential pressure is transmitted to the building due to the check valve. The use of variable-speed drives makes hydraulic independence of little value.

Simply deleting the common leg is similar to adding the check except that now the secondary and tertiary pumps are always in series. Again, with variable-speed drives, this should not cause any hydraulic problems (Rishel 1988).

For new systems, by far the best solution is not to have tertiary pumps or, rather, not to have conventional secondary pumps. Figure 3 shows the same building complex as Figure 1 but with secondary pumps moved out to what was formerly the tertiary pump position. The common leg for the system is still back at the central plant. Building pumps are sized to handle the head from the plant to and through the building then back to the plant. This design not only eliminates the problems associated with bypass connections, it reduces pump energy by allowing secondary pumps to be sized just for the head required for the building they serve, rather than the highest-head circuit for which the secondary pumps in Figure 1 must be sized. For large coils (shown in the Figure 3 as Building B), two-way control valves may be eliminated and the variable speed driven pump can be used to directly control flow through the coil (pump speed is controlled by the same controller that would have controlled the two-way valve). This reduces pump head by eliminating the control valve pressure drop (typically on the order of 10 to 15 feet) and by allowing cube-law energy savings through the whole range of flow through the coil (typical VFD control maintains a fixed minimum differential pressure that allows only linear reductions in pump power at low flows). Blending, if desired to maintain higher supply water temperatures (e.g., for process loads), can still be accommodated by adding a blending bypass valve (as shown in Building C in Figure 3).

Uncontrolled Process Loads

A chiller plant in an industrial environment may serve process loads in addition to cooling coils. Some process equipment has no flow control devices and, hence, uses as much

chilled water when it is “on” as it does when it is “off.” This is not always clear to the designer; he or she is directed to deliver so much chilled water to a process device, but it is not clear what happens inside the device and whether it includes any modulating or shutoff controls. When controls are lacking, chilled water delta-T falls whenever these process systems are not at full load.

Mitigation: The designer should work with the process equipment supplier to determine if controls are present, and if not, whether external, field mounted shutoff valves may be installed.

Some process equipment does not require the low chilled water temperatures typical of HVAC loads. If the equipment can be served with water in the 50s, supply return chilled water instead of supply water using a pump piped in a primary-secondary (or secondary/tertiary) manner as in Figure 4. This will increase system delta-T even further and will require no increase in plant chilled water pumping capacity.

CAUSES THAT CAN BE RESOLVED BUT MAY NOT RESULT IN OVERALL ENERGY SAVINGS

Laminar Flow

Heat transfer coefficient on the water side of the coil is primarily a function of flow turbulence, which is described by the Reynolds number, a dimensionless number defined as

$$Re = \frac{VD\rho}{\mu} \tag{2}$$

where *V* is the tube velocity, *D* is the tube diameter, ρ is density of the water, and μ is the viscosity.

The water-side heat transfer characteristics of coils are not well understood. Many papers on low delta-T problems have attributed the problem in part to a sudden drop in heat

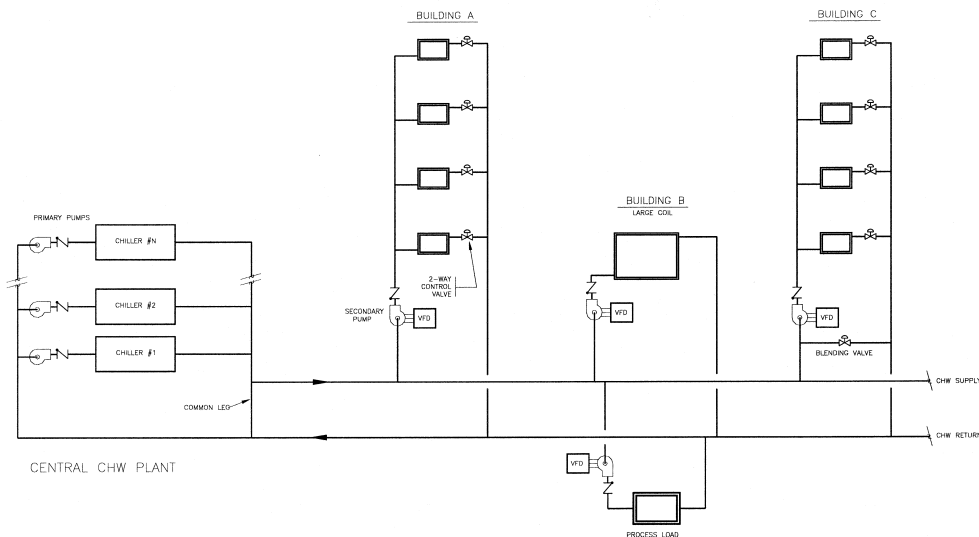

Figure 3 Chilled water plant with remote secondary pumps.

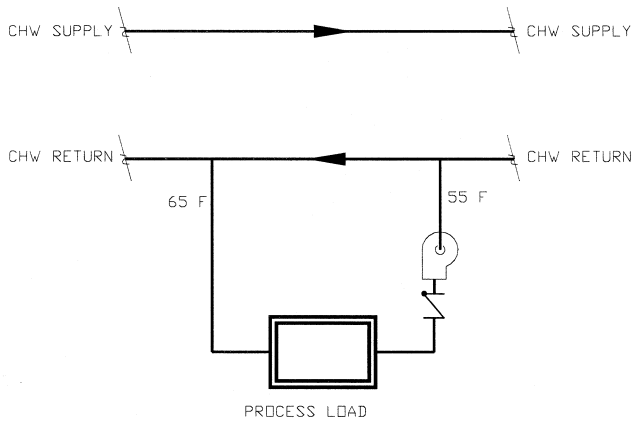

Figure 4 Process load piped to CHW return. Many process loads do not require chilled water in the 40s. If warmer water is acceptable, piping the load in a primary-secondary manner can improve plant delta-T.

transfer coefficient as flow goes from the turbulent regime to the laminar flow regime when the Reynolds number drops below about 2000. However, this is based on a simplistic coil model that neglects the fact that coil tubes are not infinite in length. Coil bends at the end of each row cause flow to be turbulent even when the velocity is below that which would normally correspond to laminar flow in long tubes. According to ARI Standard 410 (ARI 1991), for coils with smooth tubes, there are three flow regimes:

- Fully developed turbulent flow ($Re \geq 10,000$). This high a Reynolds number seldom occurs in coils (or in typical HVAC piping systems in general).
- Transitional flow ($2100 \leq Re < 10,000$). This is the most common flow regime for typical coils and HVAC piping.
- Laminar flow ($Re < 2100$). This occurs at low flow rates (low loads).

Figure 5 shows this effect on heat transfer factor J (defined as $St Pr^{2/3} (\mu_s/\mu)^{0.18}$ where St is the Stanton number, Pr is the Prandtl number, and the subscript s refers to the conditions at the inside surface of the tube) for two typical coils, one 12 feet long and one 2 feet long. At high, turbulent flow rates, J is the same for both coils. As velocity decreases into the transition region, the heat transfer factor begins to fall, but less so for the shorter coil because the tube bends tend to keep flow more turbulent. At the onset laminar flow, the heat transfer factor begins to rise. Figure 6 shows the same data with the heat transfer factor converted to percent of design of the film heat transfer resistance at the inside surface of the tube and Reynolds number converted to percent of design flow rate. Film heat transfer resistance is only a small portion of the overall air-to-water heat transfer resistance at the design flow rate, but as water velocity falls, this resistance rises until, at laminar

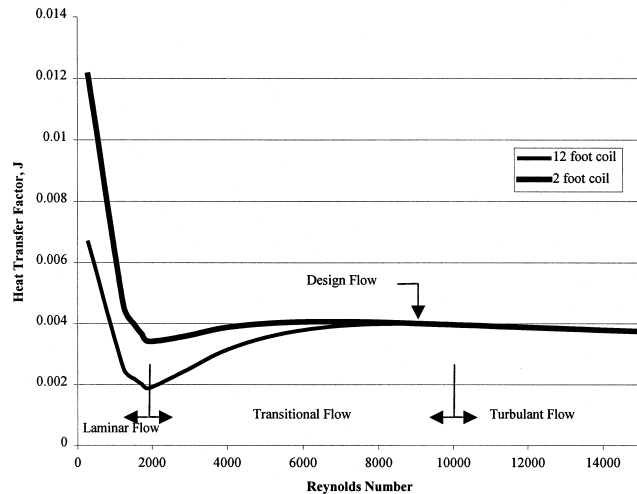

Figure 5 Heat transfer factor as flow varies. This coil was selected for 3 fps design velocity with 5/8 in. tubes. In this case, the coil never experiences fully developed turbulent flow; the design condition is already in the transition region. Laminar flow occurs at 0.5 to 0.8 fps, roughly 20% to 25% of design flow. Data obtained from coil manufacturer selection program correlated to measured coil data under low flow conditions.

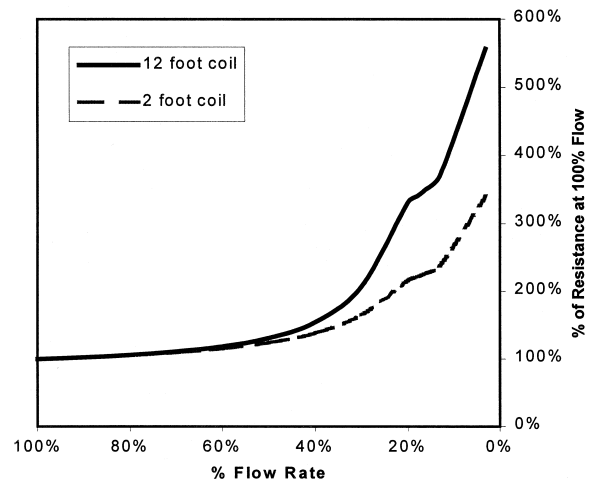

Figure 6 Heat transfer resistance as flow varies. This coil is the same as the one in the previous figure with heat transfer factor converted to percent of design the film heat transfer resistance at the inside surface of the tube and Reynolds number converted to percent of design flow rate.

flow conditions, it accounts for almost 90% of the overall resistance.

There is no sudden rise in heat transfer resistance as traditional theory predicts. However, the significant increase in film resistance at low flows would still support the notion that delta-T in the laminar flow region should fall. But there is

another factor occurring at the same time that more than offsets this rise in heat transfer resistance: the low flow rate through the coil effectively “sees” an oversized coil, a large amount of heat transfer surface area relative to the amount of water running through the coil. The water stays in the coil longer and more heat transfer occurs, which causes temperature rise to increase rather than decrease. Figure 7 shows delta-T as a function of space sensible load in a VAV system for three coil types. The effect of increasing coil effectiveness due to the reduced flow rates overcomes the increase in film resistance so that coil delta-T remains above design delta-T except at the transition point into the laminar flow regime. Contrary to conventional thinking, delta-T below the onset of laminar flow increases rather than decreases.

The point at which delta-T begins to fall is a function of initial coil tube velocity, but it typically is at around 40% of load for VAV systems and 50% of load for constant volume systems. The point is lower for variable volume systems because the supply air temperature on these systems typically remains fairly constant at near design conditions (keeping approach temperature difference constant even at reduced loads) and the airflow rate falls (reducing air-side heat transfer coefficient). Thus, coil effectiveness is less than for constant volume systems, requiring higher flow rates for the same space load.

Mitigation: The laminar flow “problem” so often referenced in the literature does not appear to be a real problem. Yes, delta-T will fall near the transition to laminar flow, but it is still very near design delta-T. During most low-load flow conditions, delta-T will be above design delta-T. Laminar flow

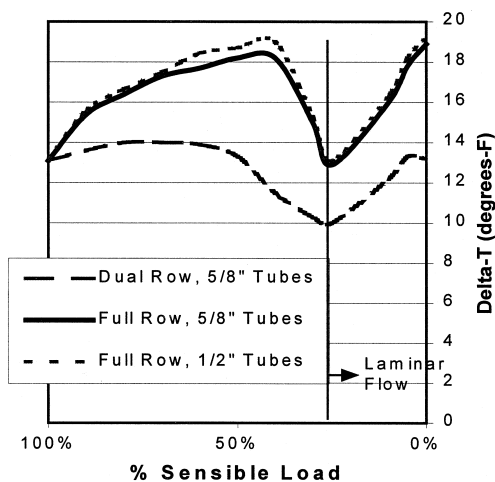

Figure 7 Delta-T at part load. Coils shown were selected for a 13°F design delta-T. Load reduction is first by reducing volume to 40%, then reducing entering air temperature. Leaving air temperature is constant, as per standard VAV systems. Performance determined by coil manufacturer’s expanded simulation program, allowing simulation below the laminar region.

effects are, therefore, unlikely to be a major source of degrading delta-T syndrome.

Many articles that referenced laminar flow as a problem proposed as a solution the addition of a tertiary (or “quadri-ary”) pump at each coil, piped to maintain a constant water velocity through the coil (Figure 8). This will ensure flow is at the design rate, nearly fully turbulent, eliminating any laminar flow effects. However, first costs and maintenance costs will increase substantially and, ironically, pump energy costs will also increase substantially, counter to one of the primary goals for installing the coil pumps. The reason is that the coil pumps are constant volume (constant energy) and, because of their small size, they are inherently less efficient than the larger secondary pumps. Also, total head on the system will increase due to the added valves, fittings, etc., required to install the coil pumps. These penalties are sufficient to more than offset the reduced secondary pump energy provided by the higher delta-Ts at low load.

Tube diameter has only a minor impact on coil part-load performance. One would think that smaller tubes would increase tube velocities for the same flow rate and, hence, keep turbulence and associated heat transfer coefficients high. Also, since velocity is inversely proportional to the square of the diameter for a given flow rate, Equation 2 indicates that a smaller tube diameter would reduce the flow rate at which laminar flow occurs. However, when tube size is reduced in a real coil, more tubes are used, so the velocity increase is not as dramatic as one might expect. Figure 7 shows that typical coils with 1/2-inch tube diameter do outperform the coil with 5/8-inch tubes, but only slightly. The percentage of flow at which

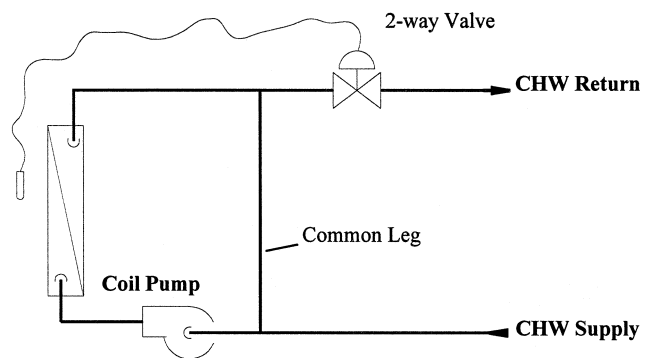

Figure 8 Pumped coil. Coil is piped in a traditional primary-secondary manner. The control valve is modulated in the same manner as it would without the pump (e.g., off of supply air temperature, as shown, or off of space temperature.) The pump maintains constant flow through the coil regardless of the operation of other pumps upstream or the position of the control valve. Constant flow eliminates laminar flow effects.

laminar flow occurs for these particular coils drops from about 29% of design for the 5/8-inch tubes to 27% for 1/2-inch tubes. The higher pump heads caused by the higher water-side pressure drop associated with 1/2-inch tubes will almost surely offset any pump energy savings due to this slight increase in performance.

The selection of 1/2-inch-diameter or 5/8-inch tubes will hinge on first costs versus pump head requirement at full load. The impact of this choice on delta-T is very small, and should not be a consideration.

Chilled Water Reset

Chillers are more efficient at higher leaving water temperatures, so resetting chilled water temperature upward at low loads can be an effective energy-saving strategy. However, high chilled water temperature will reduce coil performance and, hence, coils will demand more chilled water, lowering delta-T. Table 2 shows this effect: coil flow rate almost doubles when CHW supply temperature is increased from 42°F to 48°F.

Mitigation: The best chilled water reset strategy will vary depending on the plant design, chiller performance characteristics, and the nature of coil loads. Smaller plants, those with low pumping distribution losses, will usually benefit from chilled water reset. For large plants with high pumping distribution losses, raising chilled water temperature will increase pumping energy more than it reduces chiller energy, resulting in a net increase in plant energy usage. These plants may benefit from lowering the chilled water setpoint even below design levels in mild weather. A complete analysis of these various options is beyond the scope of this paper.

CAUSES THAT CANNOT BE AVOIDED

Reduced Coil Effectiveness

Coil heat transfer effectiveness is reduced by water-side fouling (e.g., slime, scale, or corrosion on the inside of coil tubes), air-side fouling (e.g., dirt buildup on coil fins), and air-side deterioration (e.g., deteriorating fins). Any reduction in coil effectiveness increases the flow rate of water required to deliver the desired leaving water temperature, thus reducing delta-T.

Another related problem is a reduction in air flow caused by, for example, dirty filters. This reduces air-side heat transfer coefficients and reduces the overall space cooling capacity of the system. The space thermostat then causes the chilled water valve to increase water flow rates to deliver colder supply air temperatures to compensate for low air flow, thus reducing delta-T.

Mitigation: Water-side fouling is easily controlled with water treatment at the time the system is filled. Since the system is generally closed, water treatment need not be a large, ongoing expense. If, however, the system has considerable leaks or otherwise requires considerable make-up water, water treatment should be automated to ensure its adequacy.

Air-side fouling is usually minimized by good filtration. Filters should be at least 30% dust-spot efficiency (or MERV 6 or 7 using the new ASHRAE 52.2 rating method).

Outdoor Air Economizers and 100% Outdoor Air Systems

One issue very often overlooked as a cause of degrading delta-T on systems designed for high delta-Ts (e.g., above 14°F) is the impact of integrated outdoor air-side economizers and 100% outdoor air systems. When the weather is cool but not cold enough to provide 100% of the system cooling load, these systems deliver 100% outdoor air but need a small amount of chilled water to meet cooling demands. Under these conditions, the air temperature entering the coil is low, causing correspondingly low return water temperatures. For instance, a coil might be designed for 80°F entering air temperature with a chilled water return temperature of 60°F. When the outdoor air temperature is 60°F, it is clearly impossible to maintain a 60°F return water temperature. A coil on a VAV system designed for 44°F chilled water and an 18°F delta-T would only be able to achieve an 11°F to 15°F delta-T at 55°F to 65°F outdoor air temperatures.

Mitigation: The impact of low coil entering air temperature can be mitigated by using a lower design delta-T. However, this will increase pump energy under all operating conditions, so it clearly is not a reasonable solution.

ACCOMMODATING LOW DELTA-T

The causes of low delta-T due to improper design, operation, or maintenance can and should be eliminated. But even with a perfectly designed, operated, and maintained system, there are still factors, such as the impact of air economizers and coil effectiveness degradation as systems age, that will result in degrading delta-T. Degrading delta-T is inevitable.

In the author's experience, delta-Ts in real systems, due to a combination of the factors listed above, can be expected to fall to about one-half to two-thirds of design at low loads. Figure 9 shows trend data for a large chiller plant in San Jose, California. The average delta-T was about half of the design delta-T.

If delta-T degradation is inevitable, then chiller plants must be designed to operate efficiently under high flow, low load conditions. There is nothing one can do about the increase in distribution pump energy caused by low delta-T, but here are a few ideas on how the chiller plant can be designed so that chiller energy is not impacted by low delta-T. They fall into two categories: improve chiller low-load performance so that premature staging does not affect energy use (item 1) and providing more flow through operating chillers so that they may be more fully loaded before another chiller must be brought on line (items 2 to 4).

1. *Variable-speed chillers.* Variable-speed drives on chillers dramatically improve part-load performance during low ambient conditions when condensing temperatures can be

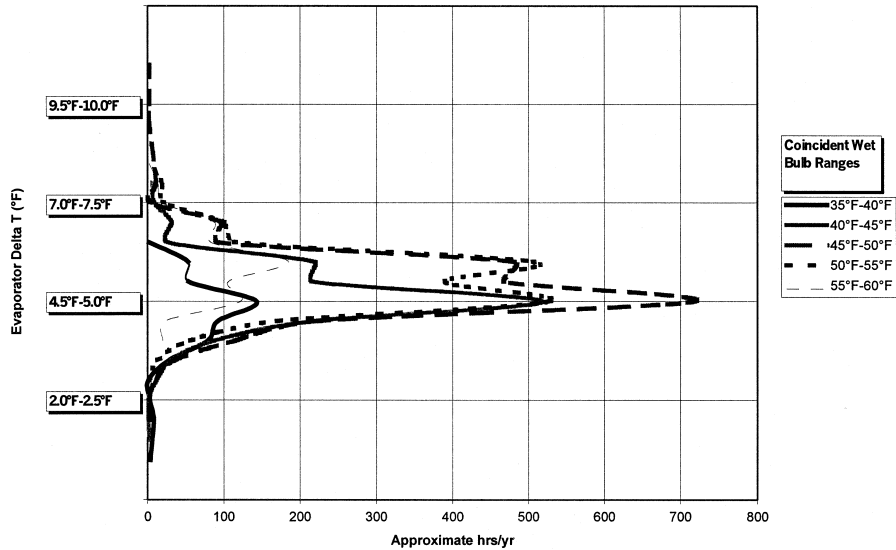

Figure 9 Degrading delta-T in large chiller plant. The design delta-T for this chiller plant in San Jose, Calif., was 10°F. This range occurred only a few hours per year.

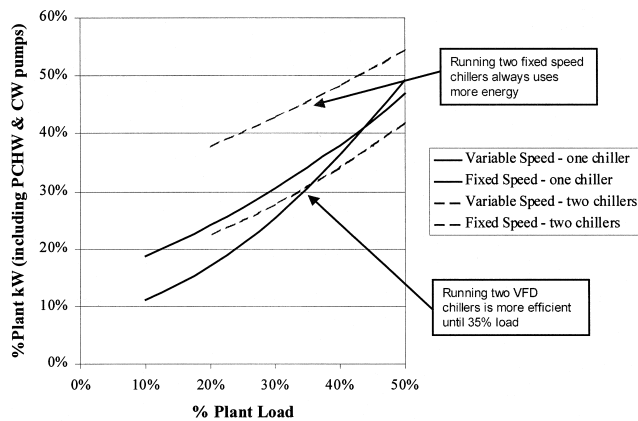

Figure 10 Variable speed vs. fixed speed chillers at part load. These data are for a two-chiller plant with equally-sized chillers and dedicated condenser water and primary chilled water pumps interlocked to start with each chiller. Chiller models did not include ARI 550/590-98 tolerances.

reduced below design conditions. Even with parasitic energy users such as interlocked condenser water and primary chilled water pumps, it is more efficient to run two chillers than one at loads above 25% to 35% of plant capacity (see Figure 10). Thus, even if low delta-T at low loads causes more chillers to operate than are required to meet the load, chiller plant energy will be no higher and can be much lower than if chillers were “maxed out” before the next chiller was started.

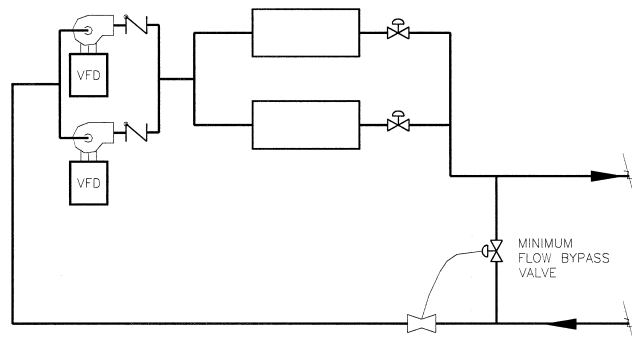

Figure 11 Primary-only pumping. Bypass valve maintains minimum chiller flow at low loads.

2. *Primary-only pumping.* An increasingly more common design in modern chilled water plants is the primary-only variable-speed pumping scheme (Figure 11). This design is less expensive to install and also reduces pump energy costs compared to primary-secondary systems, even for systems without delta-T degradation (Taylor et al. 2000; Avery 2001). The pumps also can operate more efficiently when delta-T does degrade because at low loads they have the capacity to overpump flow through the chillers, i.e., the pump head not used in the system is available to force additional flow through the chillers, increasing the load they can handle.
3. *Check valve in the common leg.* Figure 12 shows a check valve installed in the common leg between the primary and secondary systems. The check valve always keeps the primary flow greater than or equal to the secondary flow. If

the secondary flow increases beyond the capacity of the primary pumps, the check valve essentially places the primary and secondary pumps in series with each other. This causes flow through the chiller to increase along with the secondary flow. Since the primary pumps were selected for design flow and head, to increase flow beyond design rates, the secondary pumps must speed up to “draw” water through the primary loop, assisting the primary pumps in overcoming the increased pressure drop of the primary loop. Eventually, the secondary pumps will be at full speed and the system will be at the maximum flow rate it can achieve without bringing more chillers and primary pumps on line. Pumps and chillers are staged on when the secondary pumps are at full speed and beginning to starve of flow.

Depending on the pump curves and other system details, adding the check valve can cause flow through a single chiller to increase to about 140% of design rates. This is unlikely to exceed any maximum flow rate established by the chiller manufacturer.² For instance, if the chiller is sized for a 14°F delta-T, an increase in flow to 140% of design is equivalent to the rate associated with a 10°F delta-T at full load, clearly within a manufacturer’s limits. Primary pumps also are unlikely to exceed the limits of their curves with an increase of only 40% if selected as required for any non-overloading parallel-flow application.

Adding a check valve in the common leg does have one drawback: if the primary chilled water pumps are shut off or fail and the chiller isolation valves close (Figure 12), any operating secondary pumps will be dead-headed and eventually will overheat and damage seals or bearings. This can be avoided by shutting off secondary pumps should all primary pumps be off, but that is not always practical on large campus projects.

While considered heresy by fans of traditional primary-secondary systems, the check valve has proved successful at reducing chiller plant energy by as much as 20% on constant-speed chiller plants (Avery 1997). However, the valve will most likely have little or no benefit for plants with variable-speed chillers since the efficiency of these chillers is so high at low load.

4. *Unequally sized chillers/pumps.* Figure 13 is an example of how pumps and chillers can be unequally sized to provide better low-load flexibility. At low loads, either variable-

2. Manufacturers’ maximum flow rates are usually based on somewhat arbitrary maximum velocities designed to limit erosion. The author has experience with a plant that has routinely overpumped chillers at rates far above manufacturers’ recommendations for hours on end for over 20 years with no apparent problems. Limited laboratory tests also suggest that in clean systems, little erosion will occur at velocities well above what might be expected in real systems (Sturley 1975). Hence, occasional excursions above manufacturers’ limits are probably not cause for concern, and the high cost and pressure drop of flow-limiting valves can be avoided.

speed-driven pump has sufficient flow and head capacity to overpump either of the two small chillers to compensate for low delta-T. At 50% plant load and delta-Ts as low as 50% of design, both pumps can operate through the two small chillers or through the large chiller. As loads go above 50%, the large chiller and one of the small chillers can still be overpumped, although not to the same degree. This should be satisfactory since delta-T generally improves at higher loads so the need for overpumping is reduced. Above 75%, all three chillers operate. Overpumping is still possible since pump heads were oversized and pumps can ride out on their curves as they become in series with the secondary pumps due to the check valve. (The check valve is optional when primary pumps are oversized since the pumps can provide increased flow without any help from the secondary pumps.)

5. *Low design delta-T in primary loop.* If the primary loop is designed for a smaller delta-T than the secondary loop, chillers may be properly staged even with delta-T degradation in the secondary loop down to the point where the secondary delta-T degrades to the reduced primary delta-T. While this design can mitigate the energy impact of premature chiller staging, it will result in additional primary pump energy under all load conditions (even when system delta-T has not degraded) and in larger primary pumps, piping, etc. Accordingly, the other suggestions above may be more efficient and cost-effective at mitigating degrading delta-T.

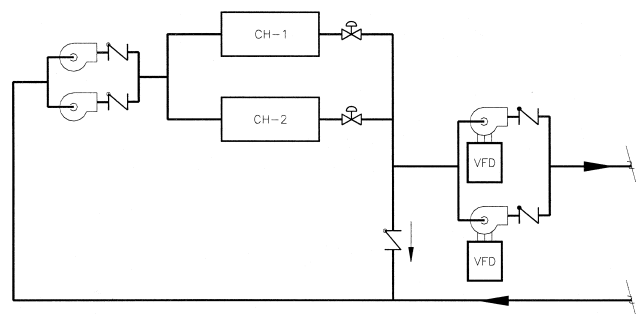

Figure 12 Check valve in the common leg.

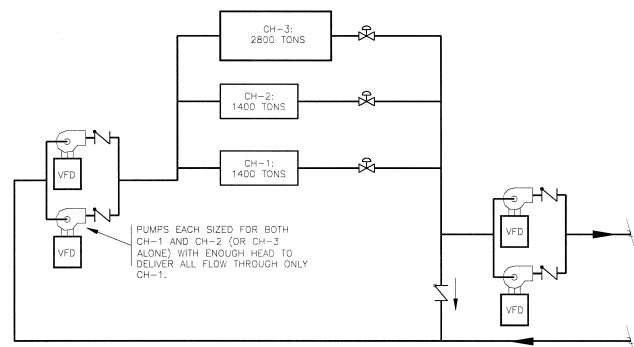

Figure 13 Unequally-sized chillers and pumps.

CONCLUSIONS

Degrading delta-T syndrome is an affliction common to almost all chilled water plants. The reasons for the problem are becoming better understood, and many can be resolved by proper design and component selection and proper operation and maintenance. But some of the causes of low delta-T are either impossible or not practical to eliminate. Therefore, the system must be designed to accommodate low delta-Ts in an efficient manner while still meeting all coil loads. This can be done by using variable-speed-driven chillers, which are so efficient at part load that under all but the lowest load conditions, it is more efficient to run more chillers than are required to meet the load. Thus, additional flow resulting from degrading delta-T will have no impact on chiller energy use. To mitigate degrading delta-T for fixed-speed chiller plants, the design must allow the chillers to be overpumped (supplied with more than design flow) so that they can be more fully loaded before staging on the next chiller. Installing a check valve in the common leg of the primary-secondary connection is one way to force increased flow through chillers since it places the primary and secondary pumps in series. Other options include sizing primary pumps for increased flow either using unequally sized pumps or with a lower design primary loop delta-T.

REFERENCES

- ARI. 1991. *Standard 410, Forced circulation air-cooling and air-heating coils*. Air Conditioning and Refrigeration Institute.
- Avery, G. 1997. Controlling chillers in variable flow systems. *ASHRAE Journal*, December.
- Avery, G. 2001. Improving the efficiency of chilled water plants. *ASHRAE Journal*, May.
- Fiorino, D.P. 1996. Twenty-five ways to raise your chilled water temperature differential. *ASHRAE Transactions* 102 (1).
- Kirsner, W. 1995. Troubleshooting chilled water distribution problems at the NASA Johnson Space Center. *Heating/Piping/Air Conditioning*, February.
- Kirsner, W. 1996. The demise of the primary-secondary pumping paradigm for chilled water plant design. *Heating/Piping/Air Conditioning*, November.
- Lizardos, E.J. 1994. Optimizing delta-T. *Engineered Systems*, September.
- Mannion, G.F. 1988. High temperature rise piping design for variable volume systems: Key to chiller energy management. *ASHRAE Transactions* 94 (2).
- Redden, G.H. 1996. Effect of variable flow on centrifugal chiller performance. *ASHRAE Transactions* 102 (2).
- Rishel, J.B. 1988. Twenty-five years' experience with variable speed pumps on hot and chilled water systems. *ASHRAE Transactions* 94 (2).
- Sauer, J.M. 1989. Diagnosing low temperature differential. *ASHRAE Journal*, June.
- Sturley, R.A. 1975. Increasing the design velocity of water and its effect on copper tube heat exchangers. *Corrosion/75*, Paper No. 58. The National Association of Corrosion Engineers.
- Taylor, S.T. 1996. *Fundamentals of HVAC control systems*. ASHRAE Self-Directed Learning Course.
- Taylor, S., P. DuPont, M. Hydeman, and C. Eley. 2000. *Cool-Tools™ Energy Efficient Chilled Water Plant Design and Performance Guide*. Pacific Gas & Electric Company.